

# G4 25000 Series Ø 25 mm (1.0-in) Can-Stack Stepper Motor Linear Actuators

High durability and exceptional performance.  
All units are built with dual ball bearings.

**Generates higher force than other competitors**

**Multiple versions available**

- Captive
- Non-Captive
- External Linear



**Specifications**

Ø 25 mm (1.0-in) Motor												
Part No.	Captive	2544	-	-	-	-	†	2554	-	-	-	†
	Non-Captive	2534	-	-	-	-	†	2584	-	-	-	†
	External Linear*	E2544	-	-	-	-	†	E2554	-	-	-	†
Wiring	Bipolar											
Step angle	7.5°					15°						
Winding Voltage	5 VDC		12 VDC		5 VDC		12 VDC					
Current (RMS)/phase	385 mA		160 mA		385 mA		160 mA					
Resistance/phase	13 Ω		72 Ω		13 Ω		72 Ω					
Inductance/phase	10.8 mH		60 mH		8.08 mH		48 mH					
Power Consumption	3.85 W											
Rotor Inertia	1.07 gcm <sup>2</sup>											
Insulation Class	Class B											
Weight	1.74 oz (49 g)											
Insulation Resistance	20 MΩ											

Linear Travel / Step 15° Step Angle			Order Code I.D.
step	inches	mm	
7.5° Angle	0.0005	0.013	3
	0.001	0.0254	1
	0.002	0.051	2
15° Angle	0.001	0.0254	1
	0.002	0.051	2
	0.004	0.102	4

Special drive considerations may be necessary when leaving shaft fully extended or fully retracted. Standard motors are Class B rated for maximum temperature of 130° C (266° F).

†Part numbering information on page 4.

**Captive Lead Screw**

Dimensions = (mm) inches

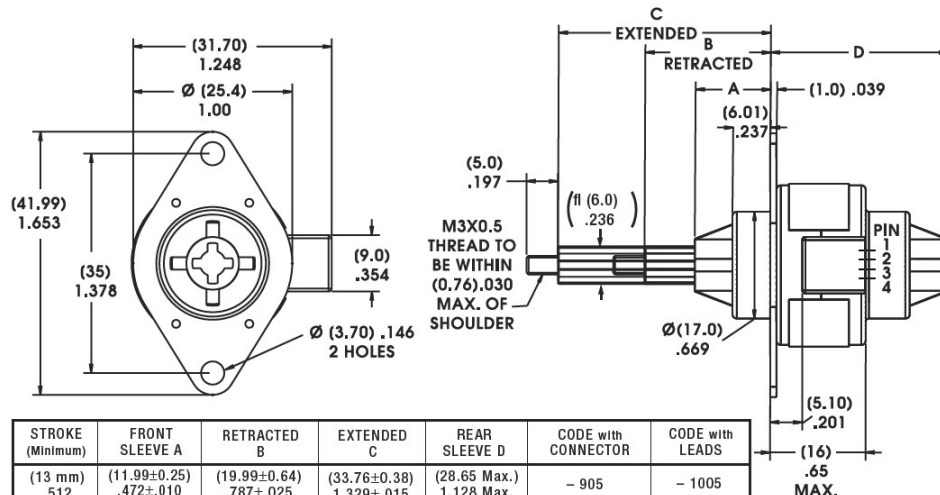

STROKE (Minimum)	FRONT SLEEVE A	RETRACTED B	EXTENDED C	REAR SLEEVE D	CODE with CONNECTOR	CODE with LEADS
(13 mm) .512	(11.99±0.25) .472±.010	(19.99±0.64) .787±.025	(33.76±0.38) 1.329±.015	(28.65 Max.) 1.128 Max.	- 905	- 1005
(18 mm) .708	(17.28±0.25) .680±.010	(25.25±0.64) .994±.025	(44.27±0.38) 1.743±.015	(33.94 Max.) 1.336 Max.	- 907	- 1007
(25 mm) .984	(24.26±0.25) .955±.010	(32.23±0.64) 1.269±.025	(58.24±0.38) 2.293±.015	(40.92 Max.) 1.611 Max.	- 910	- 1010
(31 mm) 1.22	(30.25±0.25) 1.191±.010	(38.23±0.64) 1.505±.025	(70.23±0.38) 2.765±.015	(46.91 Max.) 1.847 Max.	- 912	- 1012

### Non-Captive Lead Screw

Dimensions = (mm) inches

Up to 6.3-in (160 mm) standard screw lengths.  
Longer screw lengths are available.

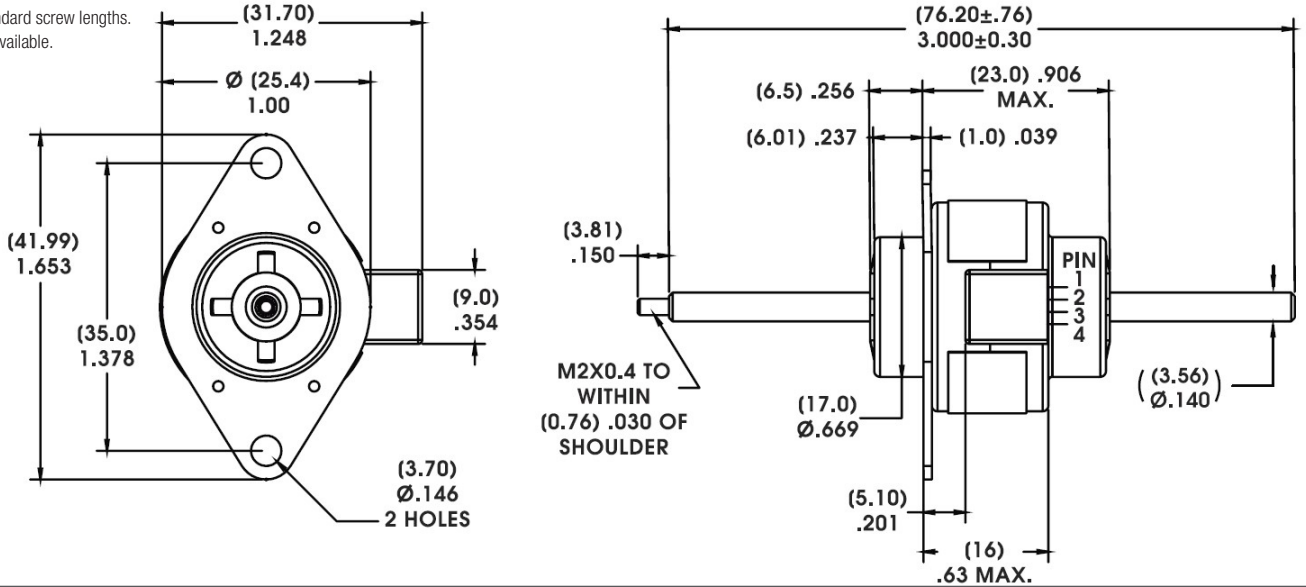

### External Linear

Dimensions = (mm) inches

Up to 6.3-in (160 mm) standard screw lengths.  
Longer screw lengths are available.

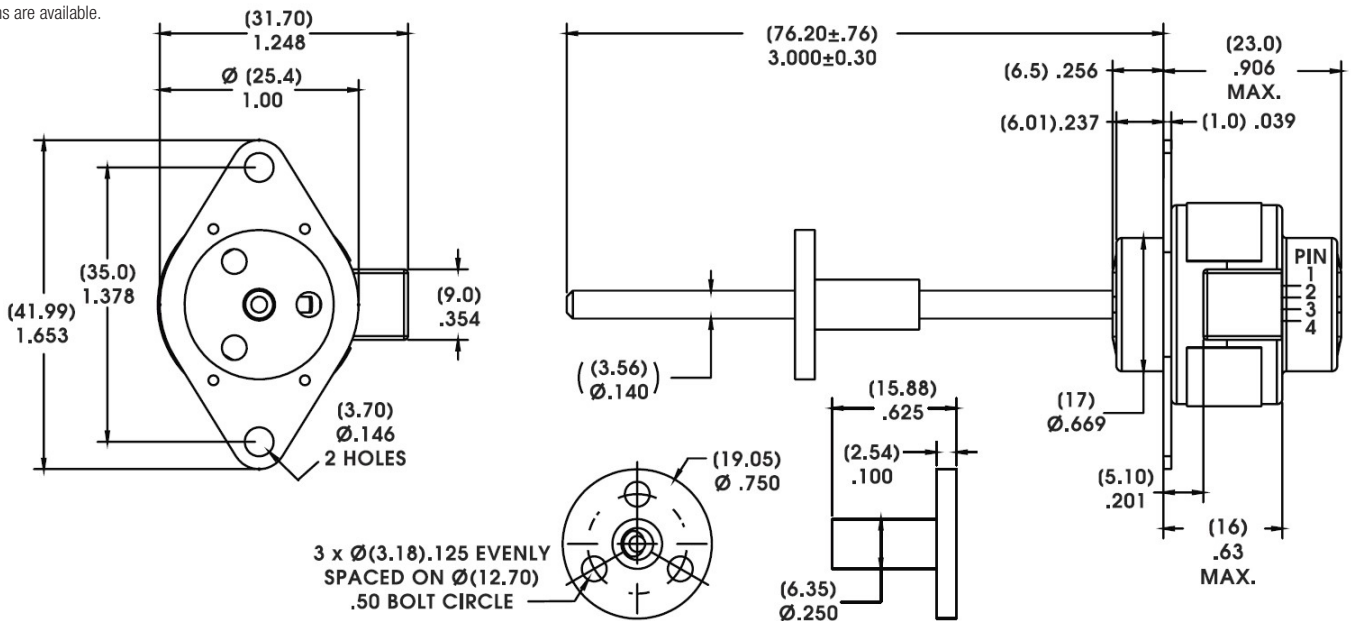

### Connector

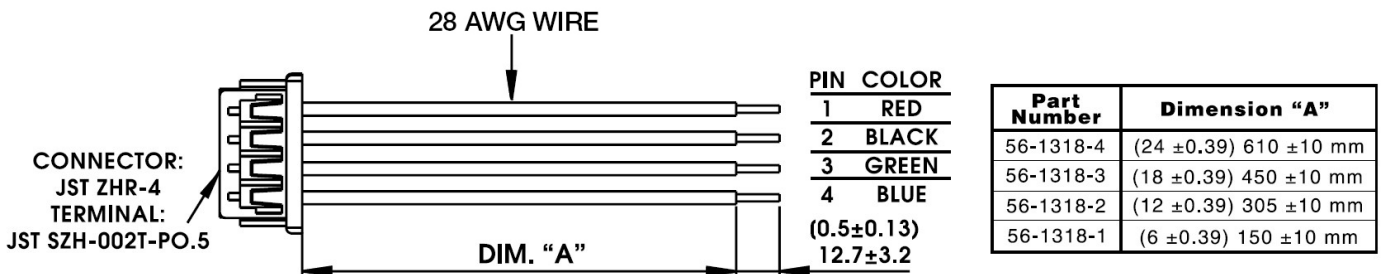

**FORCE vs. PULSE RATE**

- L/R Drive
- Bipolar
- 100% Duty Cycle

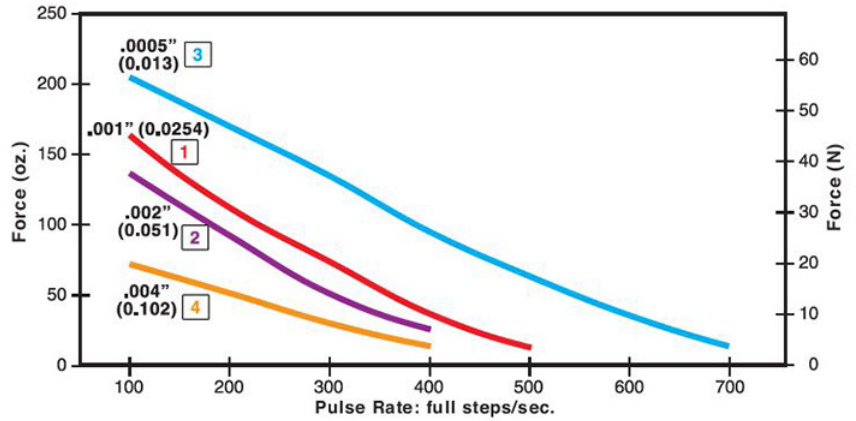

**FORCE vs. PULSE RATE**

- L/R Drive
- Bipolar
- 25% Duty Cycle

Obtained by a special winding or by running a standard motor at double the rated current.

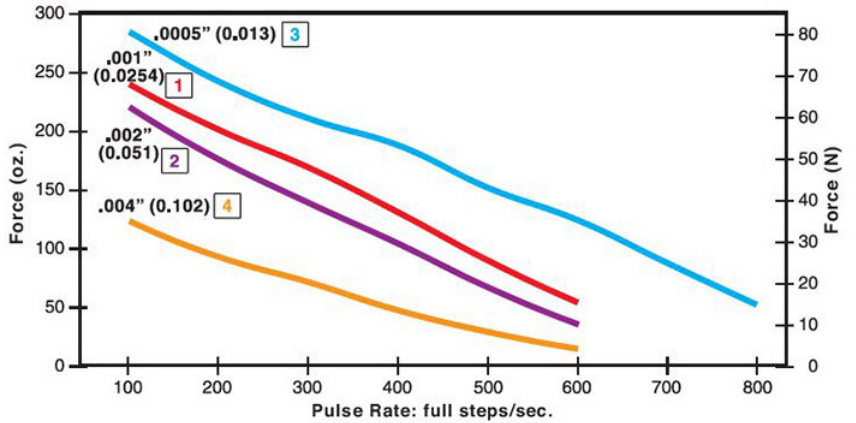

**FORCE vs. PULSE RATE**

- Chopper Drive
- Bipolar
- 100% Duty Cycle

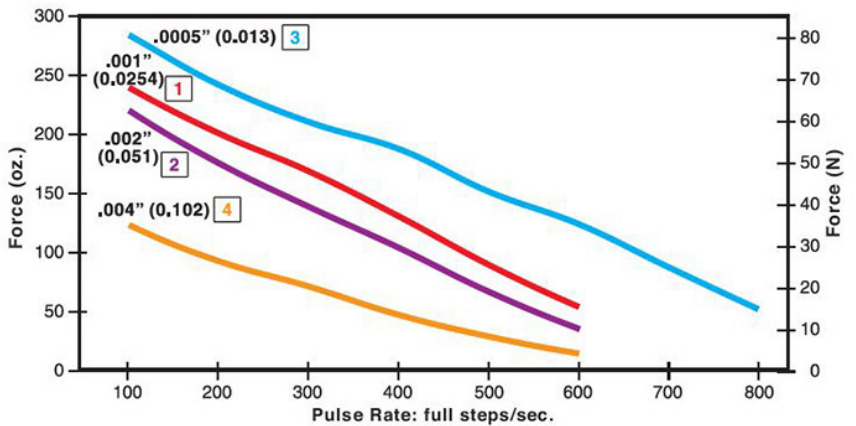

**FORCE vs. PULSE RATE**

- Chopper Drive
- Bipolar
- 25% Duty Cycle

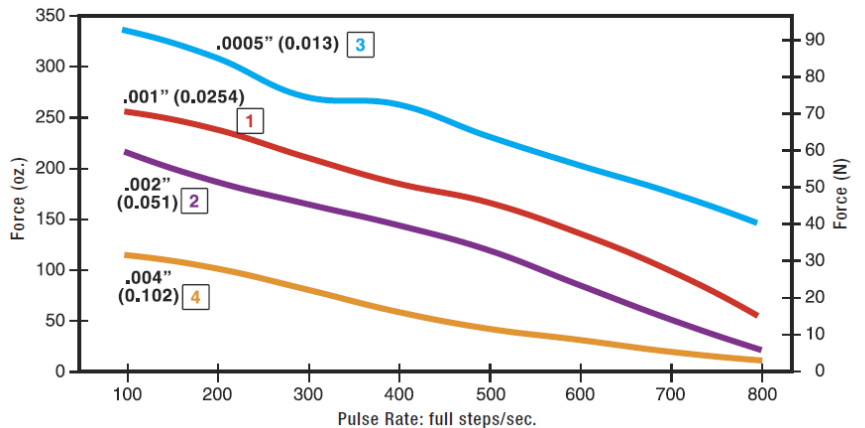

NOTE: All chopper drive curves were created with a 5 volt motor and a 40 volt power supply.

Ramping can increase the performance of a motor either by increasing the top speed or getting a heavier load accelerated up to speed faster. Also, deceleration can be used to stop the motor without overshoot.

Identifying the Can-Stack Number Codes when Ordering

E	25	5	4	4	12	1010
<b>Prefix</b> (include only when using the following) <b>E</b> = External <b>K</b> = External with 40° thread form <b>P</b> = Proximity Sensor <b>S</b> = Home Position Switch	<b>Series Number Designation</b> <b>25 = 25000</b> (Series numbers represent approximate diameters of motor body)	<b>Style</b> <b>3</b> = 7.5° Non-Captive <b>4</b> = 7.5° Captive or External (use "E" or "K" Prefix for External version) <b>5</b> = 15° Captive or External (use "E" or "K" Prefix for External version) <b>8</b> = 15° Non-Captive	<b>Coils</b> <b>4</b> = Bipolar (4 wire)	<b>Code ID Resolution Travel/Step</b> <b>1</b> = .001-in (.0254) <b>2</b> = .002-in (.051) <b>3</b> = .0005-in (.013) <b>4</b> = .004-in (.102)	<b>Voltage</b> <b>05</b> = 5 VDC <b>12</b> = 12 VDC  Custom V available	<b>Suffix Stroke</b>  Example: -1010 = captive 25mm stroke with leads -XXX = Proprietary suffix assigned to a specific customer application. The identifier can apply to either a standard or custom part.

NOTE: Dashes must be included in Part Number (-) as shown above. For assistance call our Engineering Team at 203 756 7441.

Can-Stacks: **Wiring**

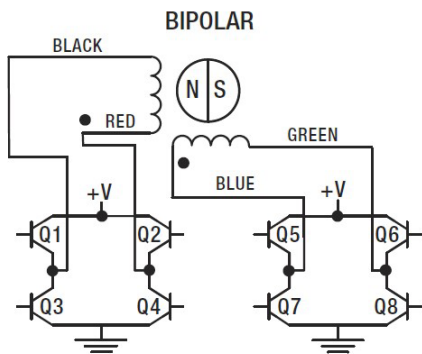

Can-Stacks: **Stepping Sequence**

Bipolar	Q2-Q3	Q1-Q4	Q6-Q7	Q5-Q8
Step				
1	ON	OFF	ON	OFF
2	OFF	ON	ON	OFF
3	OFF	ON	OFF	ON
4	ON	OFF	OFF	ON
1	ON	OFF	ON	OFF

Note: Half stepping is accomplished by inserting an off state between transitioning phases.

### TFE Coated Lead Screws for applications that require a permanent, dry lubricant

Ideal for applications where conventional oils and greases cannot be used for lead screw lubrication.

Non-lubricated TFE Coated Lead Screw provides improved performance in both life and thrust as compared to a "dry" stainless steel lead screw. TFE can be applied to a wide variety of lead screw pitches. Available captive, non-captive and external linear.

Typical applications: where contamination from grease or lubricants must be avoided; silicon wafer handling, clean rooms, medical equipment or laboratory instrumentation.

Lead Screw Comparison: FORCE vs. PULSE RATE

- L/R Drive - 100% Duty Cycle

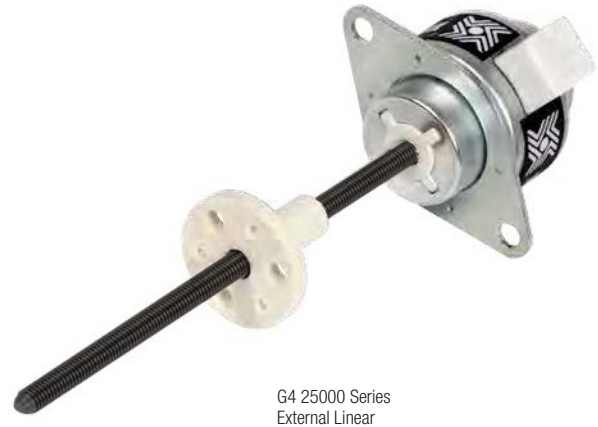
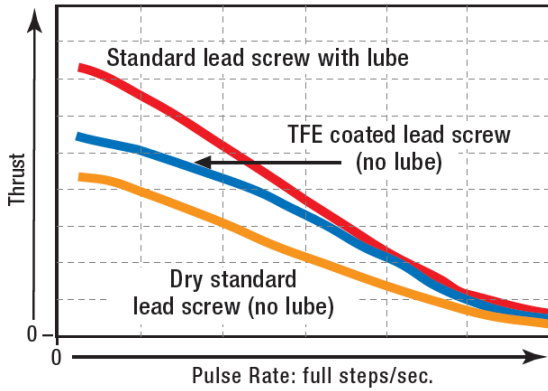

### Home Position Switch monitors movements more precisely for greater control and improved quality control

Miniature electronic home position switch capable of monitoring the home positions of linear actuators. The switch mounts on the rear sleeve of captive linear motors and allows the user to identify start, stop or home positions. Depending on your preference, contacts can be normally open or normally closed. The contact closure is repeatable to within one step position, identifying linear movements as low as 0.0005-in (0.0013 cm) per step. Multiple contact switches are also available.

Activation force of 10 oz (2.78 N) required therefore may not be appropriate for smaller can-stack actuators.

When ordering motors with the home position switch, the part number should be preceded by an "S".

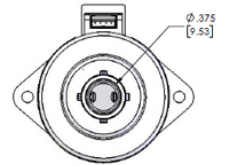
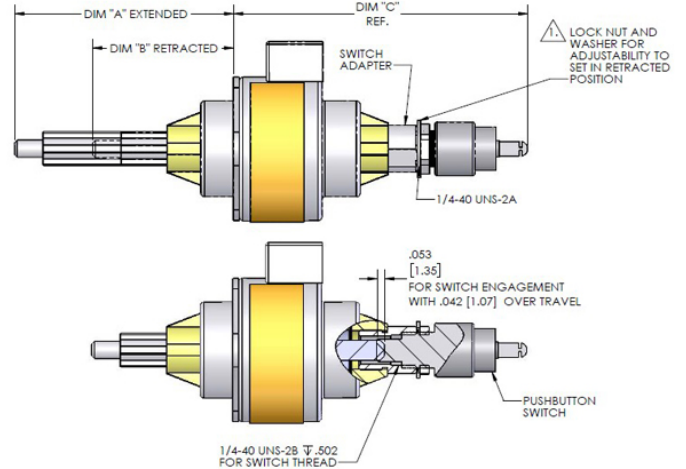

NOTE:  
ADJUST LOCATION OF LOCK NUT TO ENSURE THE RETRACTED DIMENSION

Specifications	
Contact Ratings (Standard)	1.00 AMP @ 120 VAC 1.00 AMP @ 28 VDC
Operating Temperature	-30°C to +55°C (-22°F to 131°F)
Electrical Life	< 20 milliohms typ. initial at 2 - 4 V DC, 100 mA Tested to 60,000 make-and-break cycles at full load
Schematic	 Multiple contact options available.

Stroke inches (mm)	Dim "A" Extended inches (mm)	Dim "B" Retracted inches (mm)	Dim "C" Ref. inches (mm)
.512 (13)	1.329 +/- .025 (33.76 +/- 0.64)	.787 +/- .025 (19.99 +/- 0.64)	2.051 +/- .025 (52.09 +/- 0.64)
.708 (18)	1.743 +/- .025 (44.27 +/- 0.64)	.994 +/- .025 (25.25 +/- 0.64)	2.258 +/- .025 (57.35 +/- 0.64)
.984 (25)	2.293 +/- .025 (58.24 +/- 0.64)	1.269 +/- .025 (32.23 +/- 0.64)	2.534 +/- .025 (64.37 +/- 0.64)
1.22 (31)	2.765 +/- .025 (70.23 +/- 0.64)	1.505 +/- .025 (38.23 +/- 0.64)	2.770 +/- .025 (70.37 +/- 0.64)



**End of Stroke Proximity Sensor incorporates a hall effect device, activated by a rare earth magnet embedded in the end of the internal screw**

Compact profile of the sensor allows for installation in limited space applications. Virtually unlimited cycle life. Special cabling and connectors available.

Specifications	
Supply Voltage (VDC)	3.8 min. to 24 max.
Current Consumption	10 mA max.
Output Voltage (operated)	0.15 typ., 0.40 max. Sinking 20 mA max.
Output Current	20 mA max.
Output Leakage Current (released)	10µA max. @ Vout = 24 VDC; Vcc = 24 VDC
Output Switching Time	Rise, 10 to 90% .05 µs typ., 1.5 µs max. @ Vcc = 12 V, RL = 1.6 KOhm
	Fall, 90 to 10% .15 µs typ., 1.5 µs max. @ CL = 20 pF
Temperature	- 40 to +150°C

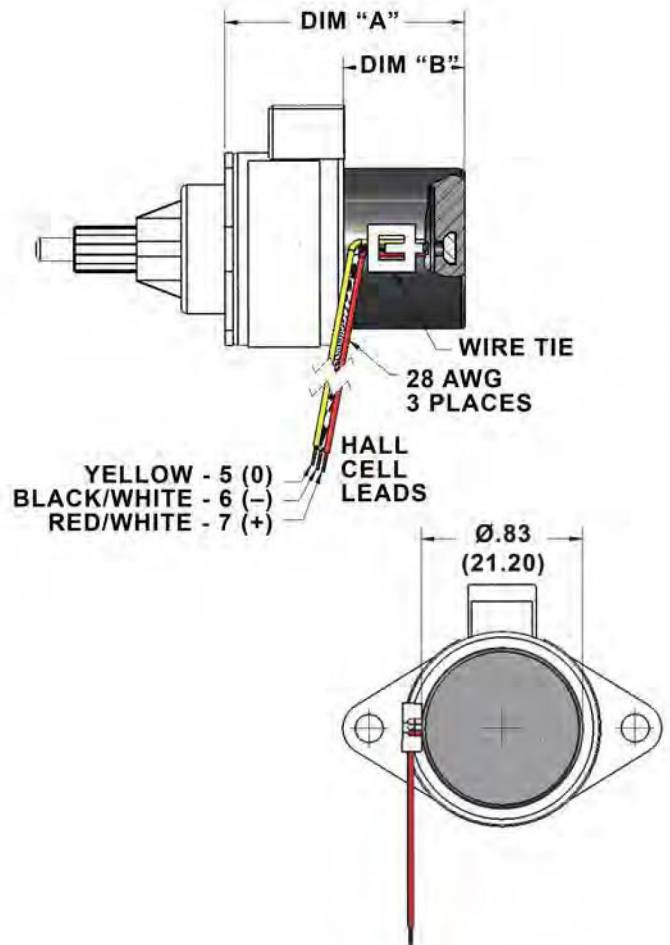
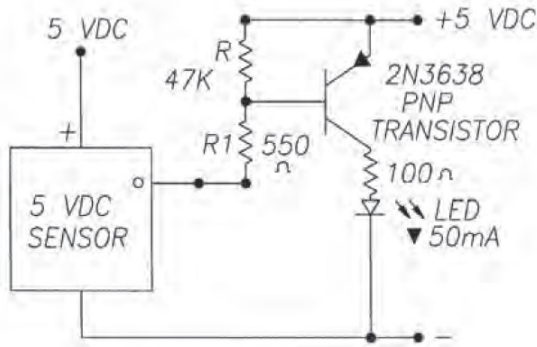

Stroke inches (mm)	Dim "A" Extended inches (mm)	Dim "B" Retracted inches (mm)
.512 (13)	1.248 (31.71)	.632 (16.05)
.708 (18)	1.449 (36.81)	.833 (21.15)
.984 (25)	1.723 (43.76)	1.106 (28.10)
1.22 (31)	1.959 (49.76)	1.343 (34.10)

The sensor has virtually unlimited cycle life. Special cabling and connectors can also be provided.

**G4 25000 Series E8T Encoder**

G4 25000 Series E8T Transmissive Optical Encoder is designed to provide the digital quadrature encoder feedback for high volume, compact space applications.

- Resolutions from 180 to 720
- Single-ended / Differential
- Frequency response to 100 kHz
- Low power consumption, 5 V @ 30 mA max
- High retention polarized connector

Assembly Options:

- Differential line driver with complementary outputs
- Detachable cable
- Through-hole cover

Stroke inches (mm)	Dim "A" Extended inches (mm)
.512 (13)	N/A
.708 (18)	N/A
.984 (25)	.071 (1.80)
1.22 (31)	.307 (7.80)

