

## 57000 Series Size 23 Hybrid Linear Actuators

**For applications that require forces up to 200 lbs. (890 N).**

Size 23 incorporates the same high performance and durable design as the Size 17.

### 3 Available Designs

- Captive
- Non-Captive
- External Linear

The 57000 Series Hybrid Linear Actuator is available in a wide variety of resolutions, from 0.0003125-in. (.0079375 mm) per step to 0.002-in. (.0508 mm) per step. They deliver a thrust of up to 200 lbs. (890 N) or speeds exceeding 2.0-in. (5.08 cm) per second.

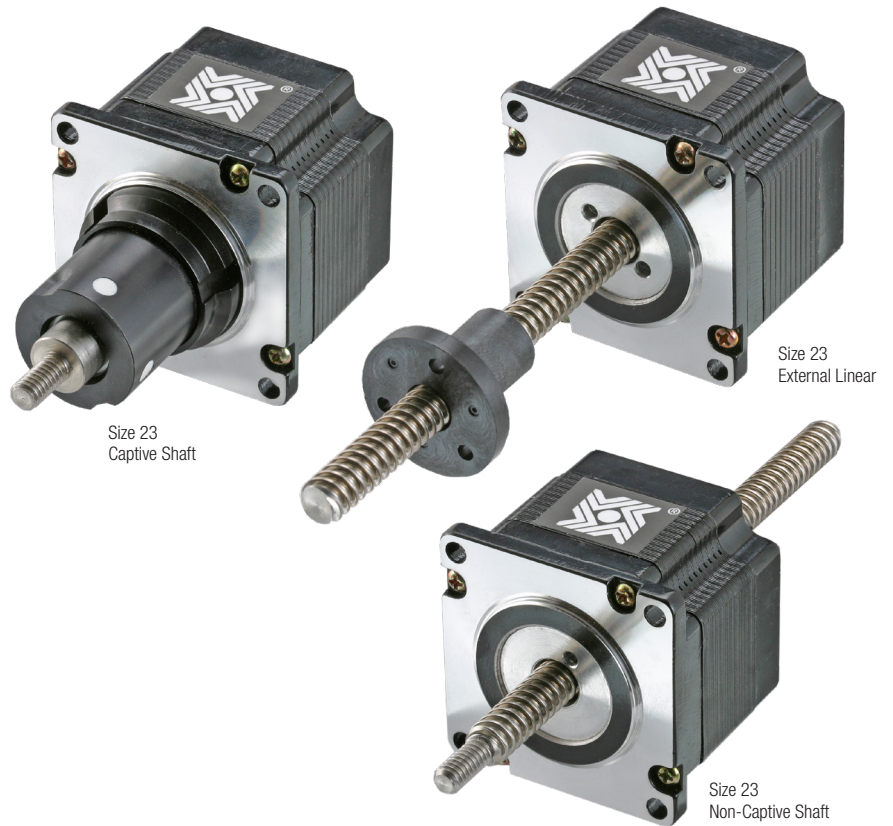

Size 23: 57 mm (2.3-in) Hybrid Linear Actuator (1.8° Step Angle)						
Part No.	Captive	57H4 [ ] – [ ] – [ ] – [ ] †			57H6 [ ] – [ ] – [ ] – [ ] †	
	Non-Captive	57F4 [ ] – [ ] – [ ] – [ ] †			57F4 [ ] – [ ] – [ ] – [ ] †	
	External Linear	E57H4 [ ] – [ ] – [ ] – [ ] †			E57H6 [ ] – [ ] – [ ] – [ ] †	
Wiring		Bipolar			Unipolar**	
Winding Voltage		3.25 VDC	5 VDC	12 VDC	5 VDC	12 VDC
Current (RMS)/phase		2.0 A	1.3 A	.54 A	1.3 A	.54 A
Resistance/phase		1.63 Ω	3.85 Ω	22.2 Ω	3.85 Ω	22.2 Ω
Inductance/phase		3.5 mH	10.5 mH	58 mH	5.3 mH	23.6 mH
Power Consumption		13 W				
Rotor Inertia		166 gcm <sup>2</sup>				
Insulation Class		Class B (Class F available)				
Weight		18 oz (511 g)				
Insulation Resistance		20 MΩ				

Linear Travel / Step		Order Code I.D.
Screw Ø .375" (9.53 mm)		
inches	mm	
.0003125	.0079*	A
.0004167	.0105*	S
.0005	.0127	3
.0008333	.0211*	T
.001	.0254	1
.002	.0508	2

\*Values truncated.  
Standard motors are Class B rated for maximum temperature of 130°C.

Special drive considerations may be necessary when leaving shaft fully extended or fully retracted.

†Part numbering information on page 5. \*\* Unipolar drive gives approximately 30% less thrust than bipolar drive.

### Captive Lead Screw

Dimensions = (mm) inches

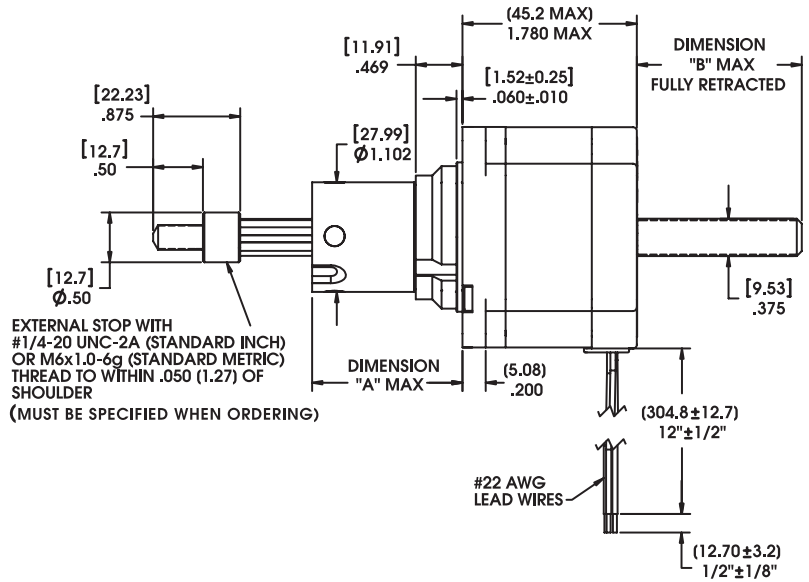
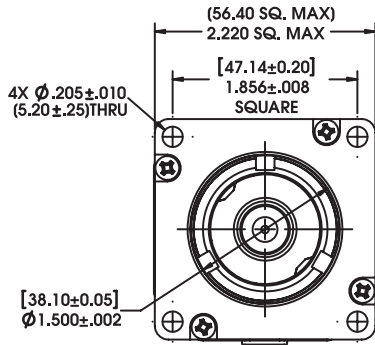

EXTERNAL STOP WITH #1/4-20 UNC-2A (STANDARD INCH) OR M6x1.0-6g (STANDARD METRIC) THREAD TO WITHIN .050 (1.27) OF SHOULDER (MUST BE SPECIFIED WHEN ORDERING)

Stroke	Dim. "A"	Dim. "B"	Suffix #	M6x1.0 thread
0.500 (12.7)	1.01 (25.7)	0.06 (1.5)	-905	-805
0.750 (19.05)	1.26 (32.0)	0.31 (7.9)	-907	-807
1.000 (25.4)	1.51 (38.4)	0.56 (14.2)	-910	-810
1.250 (31.8)	1.76 (44.7)	0.81 (20.6)	-912	-812
1.500 (38.1)	2.01 (51.1)	1.06 (26.9)	-915	-815
2.00 (50.8)	2.51 (63.8)	1.56 (39.6)	-920	-820
2.500 (63.5)	3.01 (76.5)	2.06 (52.3)	-925	-825

### Non-Captive Lead Screw

Dimensions = (mm) inches

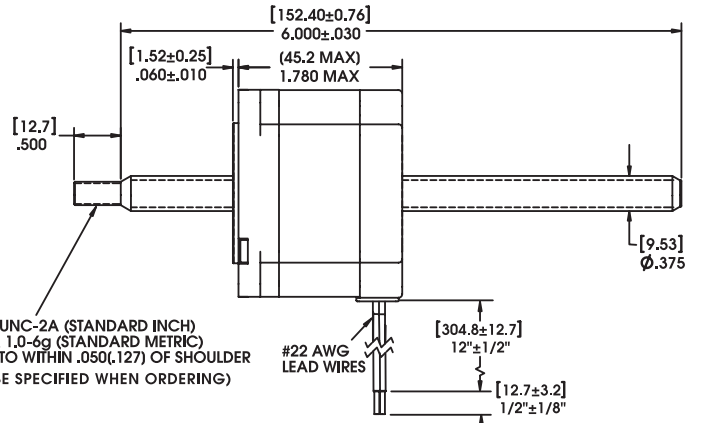
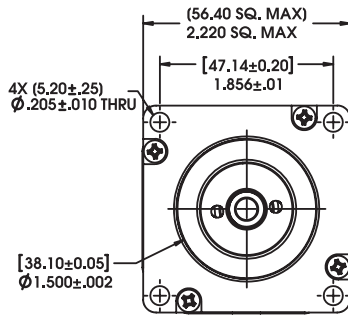

#1/4-20 UNC-2A (STANDARD INCH) OR M6 x 1.0-6g (STANDARD METRIC) THREAD TO WITHIN .050 (.127) OF SHOULDER (MUST BE SPECIFIED WHEN ORDERING)

Up to 10-in (254 mm) standard screw lengths. Longer screw lengths are available.

### External Linear

Dimensions = (mm) inches

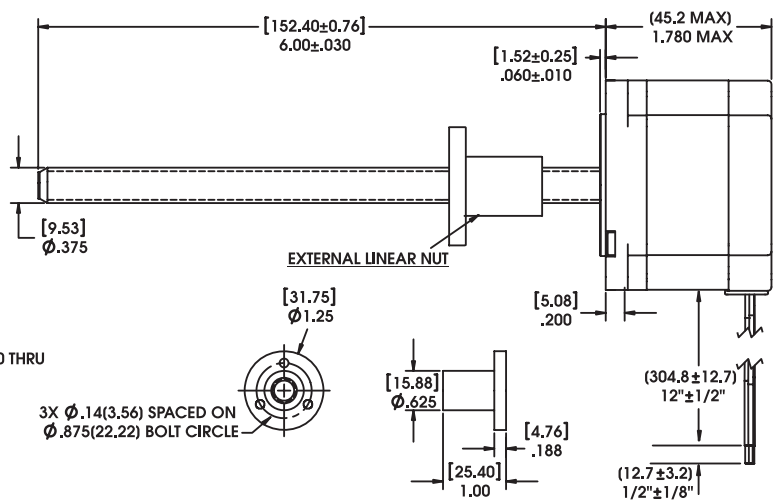
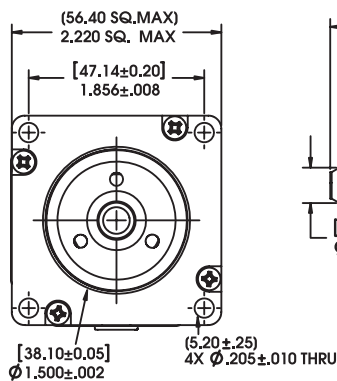

Up to 12-in (305 mm) standard screw lengths. Longer screw lengths are available.

FORCE vs. PULSE RATE – Chopper – Bipolar – 100% Duty Cycle

– Ø .375 (9.53) Lead Screw

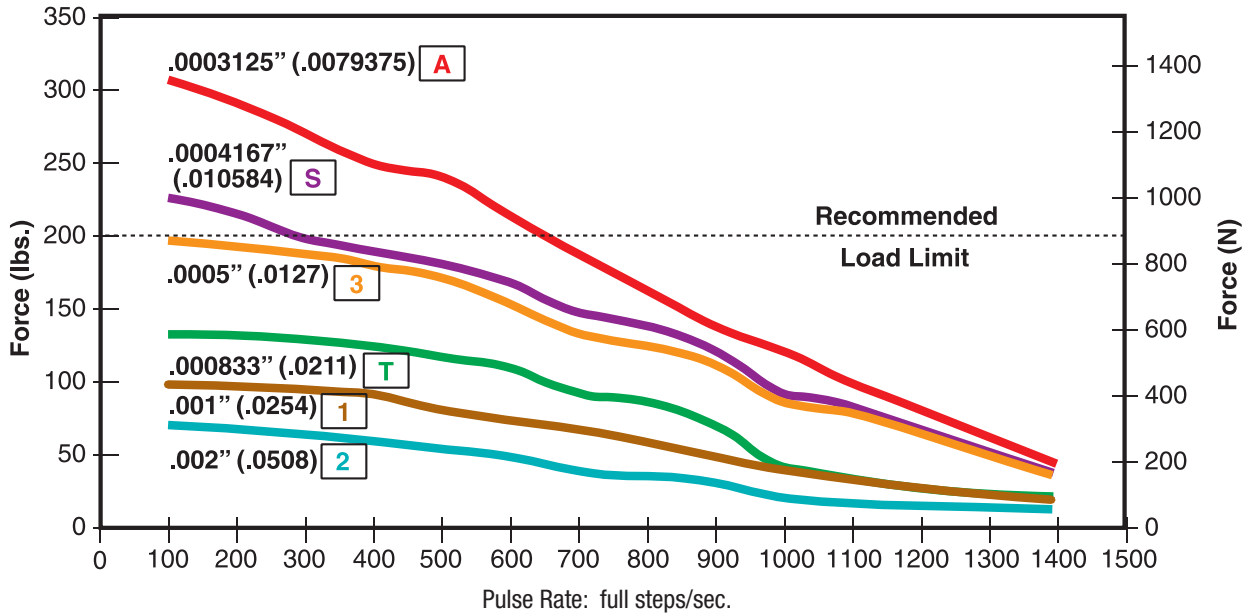

FORCE vs. LINEAR VELOCITY – Chopper – Bipolar – 100% Duty Cycle

– Ø .375 (9.53) Lead Screw

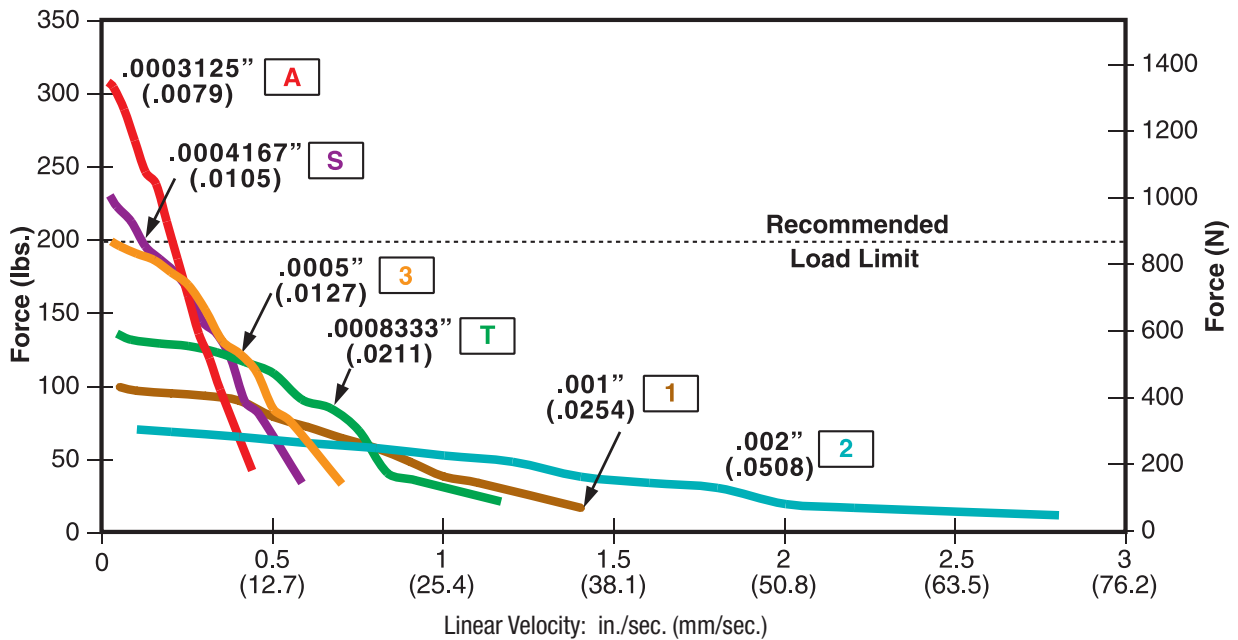

NOTE: All chopper drive curves were created with a 5 volt motor and a 75 volt power supply.





















Ramping can increase the performance of a motor either by increasing the top speed or getting a heavier load accelerated up to speed faster. Also, deceleration can be used to stop the motor without overshoot.

With L/R drives peak force and speeds are reduced, using a unipolar drive will yield a further 30% force reduction.

# 57000 Series

## Size 23, 0.9° High Resolution Motor

The Size 23, 0.9° high resolution hybrid offers precise, excellent motion control with a full linear step movement as low as 2 microns and a thrust capability up to 200 lbs (890 N).

Size 23: 57 mm (2.3-in) Hybrid Linear Actuator (0.9° Step Angle)						
Part No.	Captive	57K4  –  –  –  †			57K6  –  –  †	
	Non-Captive	57J4  –  –  –  †			57J6  –  –  †	
	External Linear	E57K4  –  –  –  †			E57K6  –  –  †	
Wiring	Bipolar			Unipolar**		
Winding Voltage	3.25 VDC	5 VDC	12 VDC	5 VDC	12 VDC	
Current (RMS)/phase	2.0 A	1.3 A	0.54 A	1.3 A	0.54 A	
Resistance/phase	1.63 Ω	3.85 Ω	22.2 Ω	3.85 Ω	22.2 Ω	
Inductance/phase	4.2 mH	13 mH	68 mH	6 mH	27 mH	
Power Consumption	13 W					
Rotor Inertia	166 gcm <sup>2</sup>					
Insulation Class	Class B (Class F available)					
Weight	18 oz (511 g)					
Insulation Resistance	20 MΩ					

Linear Travel / Step		Order Code I.D.
Screw Ø .250" (6.35 mm)		
inches	mm	
.000125	.0031*	7
.00015625	.003969	P
.00020833	.00529166	X
.00025	.00635	9
.0004167	.01058418	S
.0005	.0127	3
.001	.0254	1

\*Values truncated.

NOTE: Refer to performance curves on page 3 for codes S, 3, 1.

Special drive considerations may be necessary when leaving shaft fully extended or fully retracted.

†Part numbering information on page 5. \*\*Unipolar drive gives approximately 30% less thrust than bipolar drive.

**FORCE vs. PULSE RATE** – Chopper – Bipolar – 100% Duty Cycle  
with two available lead screw diameters

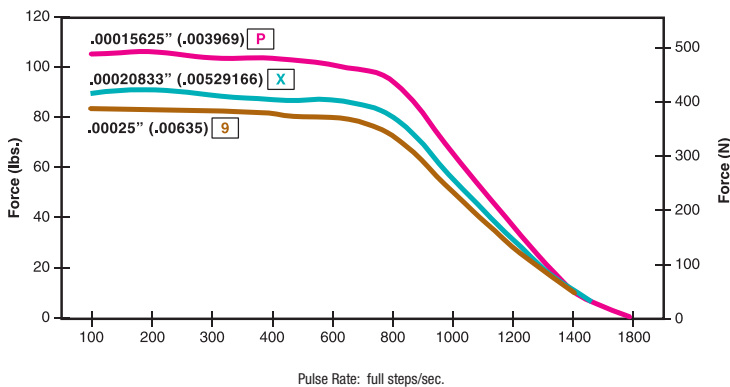

**FORCE vs. LINEAR VELOCITY** – Chopper – Bipolar – 100% Duty Cycle  
with two available lead screw diameters

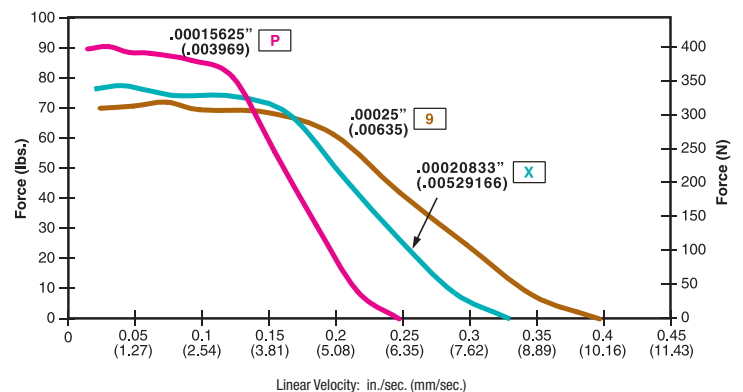

NOTE: All chopper drive curves were created with a 5 volt motor and a 75 volt power supply.

Ramping can increase the performance of a motor either by increasing the top speed or getting a heavier load accelerated up to speed faster. Also, deceleration can be used to stop the motor without overshoot.

With L/R drives peak force and speeds are reduced, using a unipolar drive will yield a further 30% force reduction.

Identifying the Hybrid Part Number Codes when Ordering

E	57	H	6	7	3.25	910
<b>Prefix</b> (include only when using the following) <b>A</b> = A Coil (See AC Synchronous Data Sheet) <b>E</b> = External <b>K</b> = External with 40° thread form <b>P</b> = Proximity Sensor <b>S</b> = Home Position Switch	<b>Series Number Designation</b> <b>57 = 57000</b> (Series numbers represent approximate width of motor body)	<b>Style</b> <b>F</b> = 1.8° Non-captive <b>H</b> = 1.8° Captive or External (use "E" or "K" Prefix for External version) <b>J</b> = 0.9° Non-captive <b>K</b> = 0.9° Captive or External (use "E" or "K" Prefix for External version)	<b>Coils</b> <b>4</b> = Bipolar (4 wire) <b>6</b> = Unipolar (6 wire)	<b>Code ID Resolution Travel/Step</b> <b>7</b> = .000125-in (.0031) <b>S</b> = .0004167-in (.01058418) <b>3</b> = .0005-in (.0127) <b>1</b> = .001-in (.0254) <b>A</b> = .0003125-in (.0079) <b>T</b> = .0008333-in (.0211) <b>2</b> = .002-in (.0508)  <b>High Resolution</b> <b>P</b> = .00015625-in (.003969) <b>X</b> = .00020833-in (.00529166) <b>9</b> = .00025-in (.0635)	<b>Voltage</b> <b>3.25</b> = 3.25 VDC <b>05</b> = 5 VDC <b>12</b> = 12 VDC Custom V available	<b>Suffix Stroke</b> Example: -910 = 1-in (Refer to Stroke chart on Captive motor series product page.)  <b>Suffix also represents:</b> -800 = Metric -900 = External Linear with grease and flanged nut -XXX = Proprietary suffix assigned to a specific customer application. The identifier can apply to either a standard or custom part.

NOTE: Dashes must be included in Part Number (-) as shown above. For assistance call our Engineering Team at 203 756 7441.

Hybrids: **Wiring**

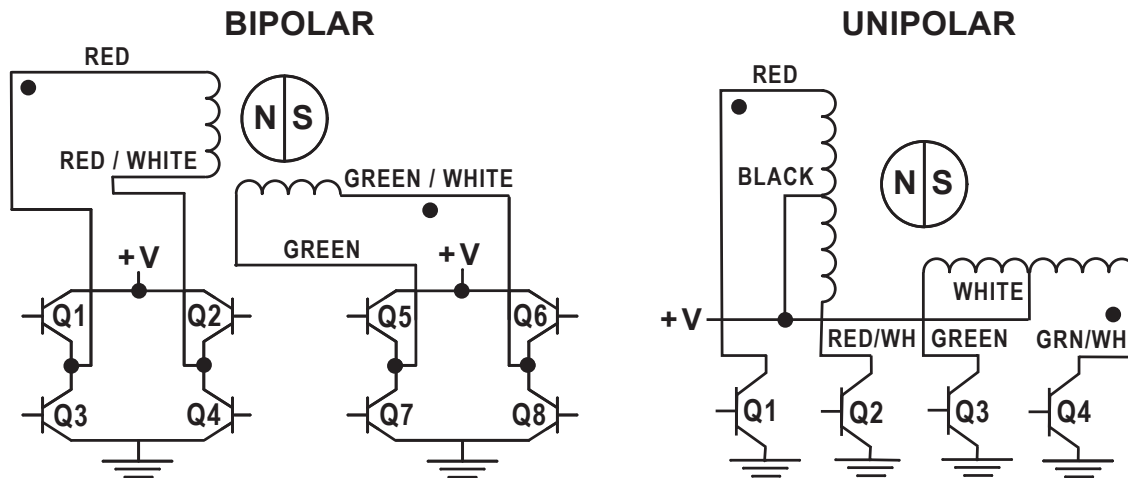

Hybrids: **Stepping Sequence**

Bipolar	Q2-Q3	Q1-Q4	Q6-Q7	Q5-Q8
Step				
1	ON	OFF	ON	OFF
2	OFF	ON	ON	OFF
3	OFF	ON	OFF	ON
4	ON	OFF	OFF	ON
1	ON	OFF	ON	OFF

EXTEND CW ↓      ↑ RETRACT CCW

Note: Half stepping is accomplished by inserting an off state between transitioning phases.

## Encoders Designed for All Sizes of Hybrid Linear Actuators

All Haydon Hybrid Linear Actuators are available with specifically designed encoders for applications that require feedback. The compact optical incremental encoder design is available with two channel quadrature TTL squarewave outputs. An optional index is also available as a 3rd channel. The Size 23 encoder is offered in resolutions of 200, 400, 1,000 and 2,000 counts per revolution. Encoders are available for all motor configurations: captive, non-captive and external linear.

Simplicity and low cost make the encoders ideal for both high and low volume motion control applications. The internal monolithic electronic module converts the real-time shaft angle, speed, and direction into TTL compatible outputs. The encoder module incorporates a lensed LED light source and monolithic photodetector array with signal shaping electronics to produce the two channel bounceless TTL outputs.

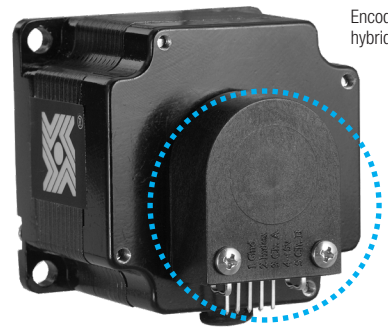

Encoder on Size 23 hybrid motor

### 57 mm 57000 Series Size 23

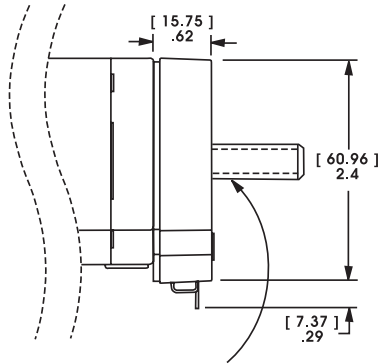

NOTE: Lead Screw extends beyond encoder on specific captive and non-captive motors. External linear shaft extension is available upon request.

Differential Ended Encoder - Pinout - Size 23	
Connector Pin #	Description
1	Ground
2	Ground
3	- Index
4	+ Index
5	Channel A -
6	Channel A +
7	+5 VDC Power
8	+5 VDC Power
9	Channel B -
10	Channel B +

Electrical Specifications				
	Minimum	Typical	Maximum	Units
Input Voltage	4.5	5.0	5.5	VDC
Output Signals	4.5	5.0	5.5	VDC

2 channel quadrature TTL squarewave outputs.  
 Channel B leads A for a clockwise rotation of the rotor viewed from the encoder cover.  
 Tracks at speeds of 0 to 100,000 cycles/sec.  
 Optional index available as a 3rd channel (one pulse per revolution).

Operating Temperature		
Size 23	Minimum	Maximum
	- 40°C (- 40°F)	100°C (212°F)

Mechanical Specifications	
	Maximum
Acceleration	250,000 rad/sec <sup>2</sup>
Vibration (5 Hz to 2 kHz)	20 g

Resolution					
4 Standard Cycles Per Revolution (CPR) or Pulses Per Revolution (PPR)					
Size 23	CPR	200	400*	1000	2000
	PPR	800	1600*	4000	8000

\*Index Pulse Channel not available.

Single Ended Encoder - Pinout - Size 23			
Connector Pin #	Description	Connector Pin #	Description
1	Ground	4	+5 VDC Power
2	Index (optional)	5	Channel B
3	Channel A		



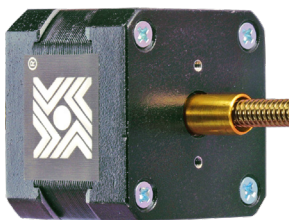

Encoder Ready Option Shown 34000 Series Size 17

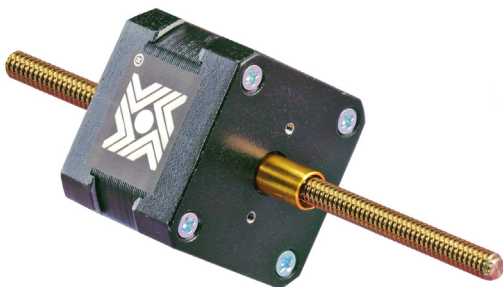

Extended Rotor Journal Shown 34000 Series Size 17

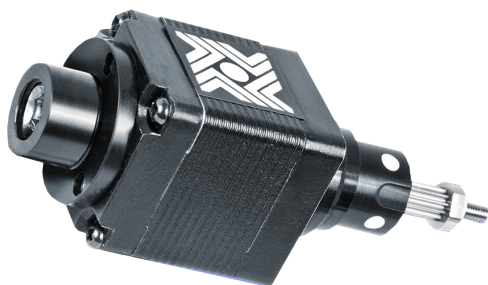

End of Stroke Proximity Sensor



TFE Coated Lead Screw

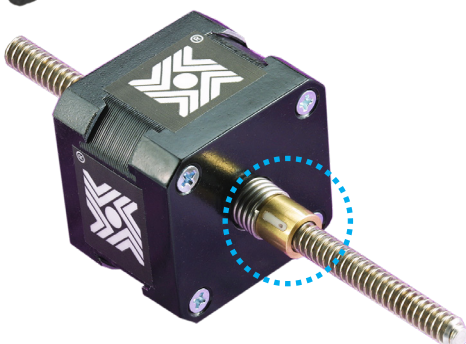

Integrated Anti-Backlash Nut

### Encoder Ready Option for all Hybrid Sizes

Our Hybrid Linear Actuators can now be manufactured as an Encoder Ready Actuator. Encoder Ready Actuators can be used to install several popular hollow shaft encoders. Available with an extended rotor journal and a threaded rear housing. The motor uses a proprietary manufacturing process which incorporates engineering thermoplastics in the rotor drive nut and a stainless steel Acme Lead Screw that allows the motor to be much more efficient and durable than today's more commonly used V-thread bronze nut configurations.

### Extended Rotor Journal for all Hybrid Sizes

Available with an extended rotor journal. The extended rotor journal can be used for encoder installation, manual adjustment, or flag installation for a positioning sensor.

### Home Position Switch for Hybrids

A miniature electronic Home Position Switch capable of monitoring the home positions of linear actuators. The switch mounts on the rear sleeve of captive linear motors and allows the user to identify start, stop or home positions.

When ordering motors with the home position switch the part number should be preceded by an "S" prefix.

### End of Stroke Proximity Sensor for all Hybrid Sizes

The Sensor incorporates a hall effect device, which is activated by a rare earth magnet embedded in the end of the internal screw. The compact profile of the sensor allows for installation in limited space applications. The sensor has a virtually unlimited cycle life. Special cabling and connectors can also be provided.

When ordering motors with the proximity sensor, the part number should be preceded by a "P" prefix.

### Black Ice® and Kerkote® TFE Coated Lead Screws\*

TFE Coated Lead Screws for applications that require a *greaseless* screw and nut interface.

A *dry* (non-lubricated) TFE coated lead screw provides improved performance in both life and thrust as compared to a conventional stainless steel lead-screw. TFE can be applied to a wide variety of lead-screw pitches and is available for our brand captive, non-captive and external linear actuators. Not available for 0.00006-in (.0015 mm) and 0.000098-in (.0025 mm) resolutions.

\*Certain conditions apply.

### Integrated Anti-Backlash Nut for Hybrids\*

Most sizes (except Size 34) of our captive and non-captive hybrid stepper motors can be equipped with an integral anti-backlash feature. There is a normal backlash between the lead screw and integral rotor nut.

Our actuators are designed for millions of cycles. However over time, additional backlash could increase and eventually double. Haydon Kerk Integrated Anti-Backlash Nut can eliminate all backlash. Designed specifically for our captive and non-captive hybrid motors, nuts use an opposing spring force to eliminate backlash between the screw and the nut interface. The nuts will self-compensate and accommodate any wear. Haydon Kerk Motion Solutions application engineers can help you select the appropriate preload for your application.

\*Except Size 34.