

87000 Series Size 34 Hybrid Linear Actuators

Our largest, most powerful linear actuator

Size 34 incorporates the same precision, high performance and durable patented designs featured in our entire hybrid product line.

3 Available Designs

- Captive
- Non-Captive
- External Linear

The 87000 series delivers forces up to 500 lbs. (2224 N) in a compact, 3.4-in (87 mm) square package. Available in a wide variety of resolutions, from 0.0005-in (.0127 mm) per step to 0.005-in (.127 mm) per step. Speeds exceed 3.0-in (7.62 cm) per second.

In addition to our standard configurations, we can custom build this powerful motor to meet your specific motion requirements.



Size 34: 87 mm (3.4-in) Hybrid Linear Actuator (1.8° Step Angle)						
Part No.	Captive	87H4 [] - [] - [] - [] †			87H6 [] - [] - [] - [] †	
	Non-Captive	87F4 [] - [] - [] - [] †			87F4 [] - [] - [] - [] †	
	External Linear	E87H4 [] - [] - [] - [] †			E87H6 [] - [] - [] - [] †	
Wiring		Bipolar			Unipolar**	
Winding Voltage		2.85 VDC	5 VDC	12 VDC	5 VDC	12 VDC
Current (RMS)/phase		5.47 A	3.12 A	1.3 A	3.12 A	1.3 A
Resistance/phase		0.52 Ω	1.6 Ω	9.23 Ω	1.6 Ω	9.23 Ω
Inductance/phase		2.86 mH	8.8 mH	51 mH	4.4 mH	25.5 mH
Power Consumption		31.2 W				
Rotor Inertia		1760 gcm ²				
Insulation Class		Class B (Class F available)				
Weight		5.1 lbs. (2.3 Kg)				
Insulation Resistance		20 MΩ				

Linear Travel / Step		Order Code I.D.
Screw Ø .625"(15.88 mm)		
inches	mm	
.0005	.0127	3
.000625	.0158*	B
.00125	.0317*	C
.0025	.0635	Y
.005	.127	Z

*Values truncated.
Standard motors are Class B rated for maximum temperature of 130°C.

Special drive considerations may be necessary when leaving shaft fully extended or fully retracted.

†Part numbering information on page 4. ** Unipolar drive gives approximately 30% less thrust than bipolar drive.

Captive Lead Screw

Dimensions = (mm) inches

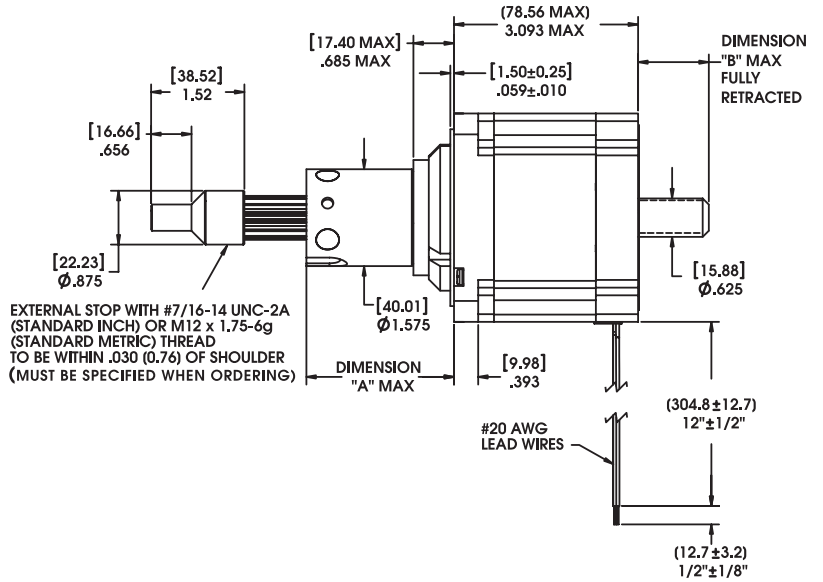
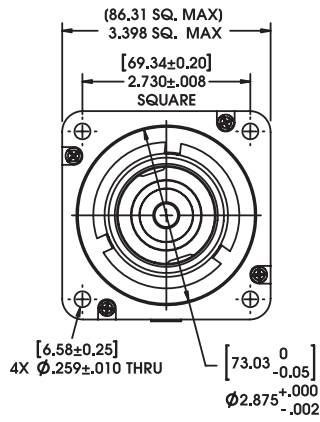

Stroke	Dim. "A"	Dim. "B"	Suffix #	M12x1.75 Thread
0.500 (12.7)	1.225 (31.12)	0 (0)	-905	-805
1.000 (25.4)	1.725 (43.82)	0.25 (6.35)	-910	-810
1.500 (38.1)	2.225 (56.52)	0.75 (19.05)	-915	-815
2.00 (50.8)	2.725 (69.22)	1.25 (31.75)	-920	-820
2.500 (63.5)	3.225 (81.92)	1.75 (44.45)	-925	-825

Non-Captive Lead Screw

Dimensions = (mm) inches

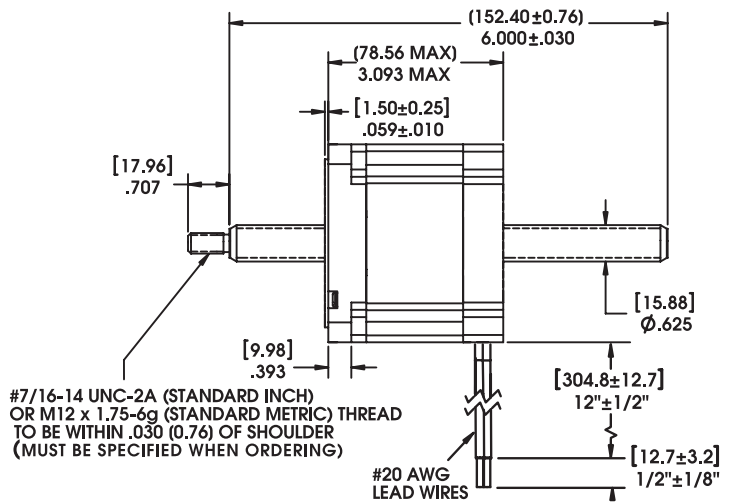
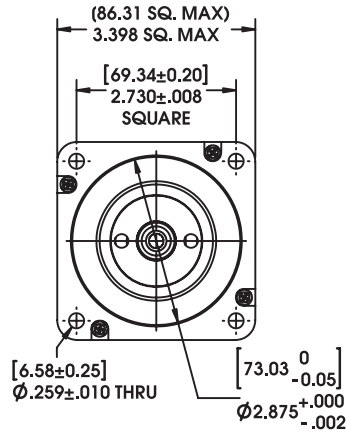

Up to 18-in (457 mm) standard screw lengths. Longer screw lengths are available.

External Linear

Dimensions = (mm) inches

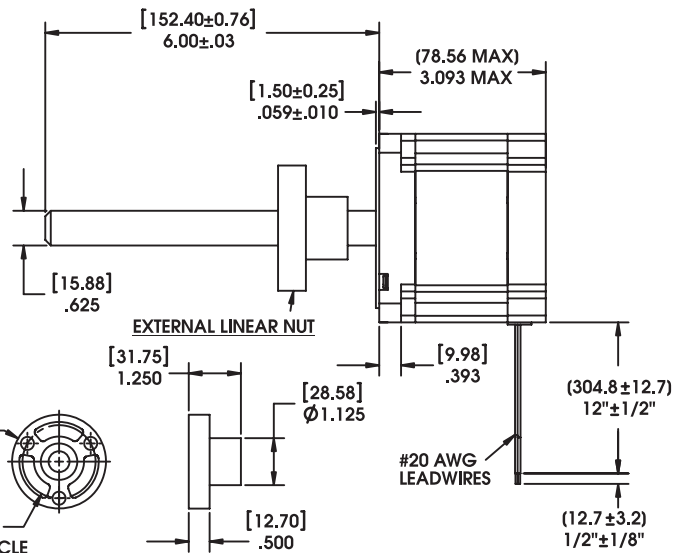
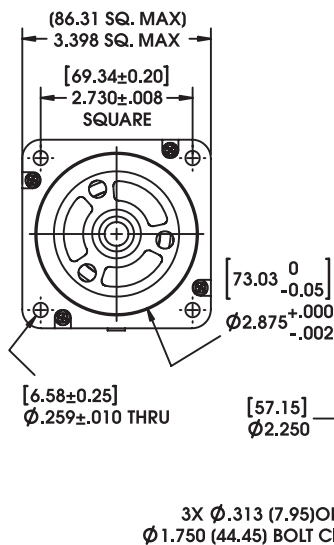

Up to 12-in (305 mm) standard screw lengths. Longer screw lengths are available.

FORCE vs. PULSE RATE – Chopper – Bipolar – 100% Duty Cycle

– Ø .625 (15.88) Lead Screw

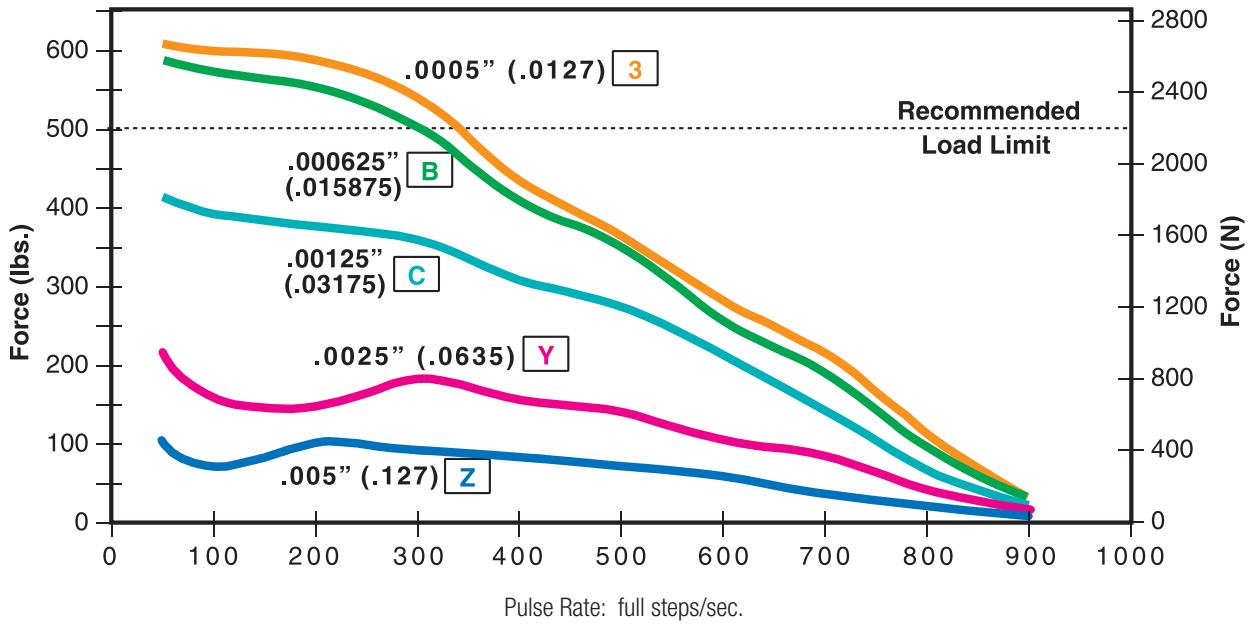

FORCE vs. LINEAR VELOCITY – Chopper – Bipolar – 100% Duty Cycle

– Ø .625 (15.88) Lead Screw

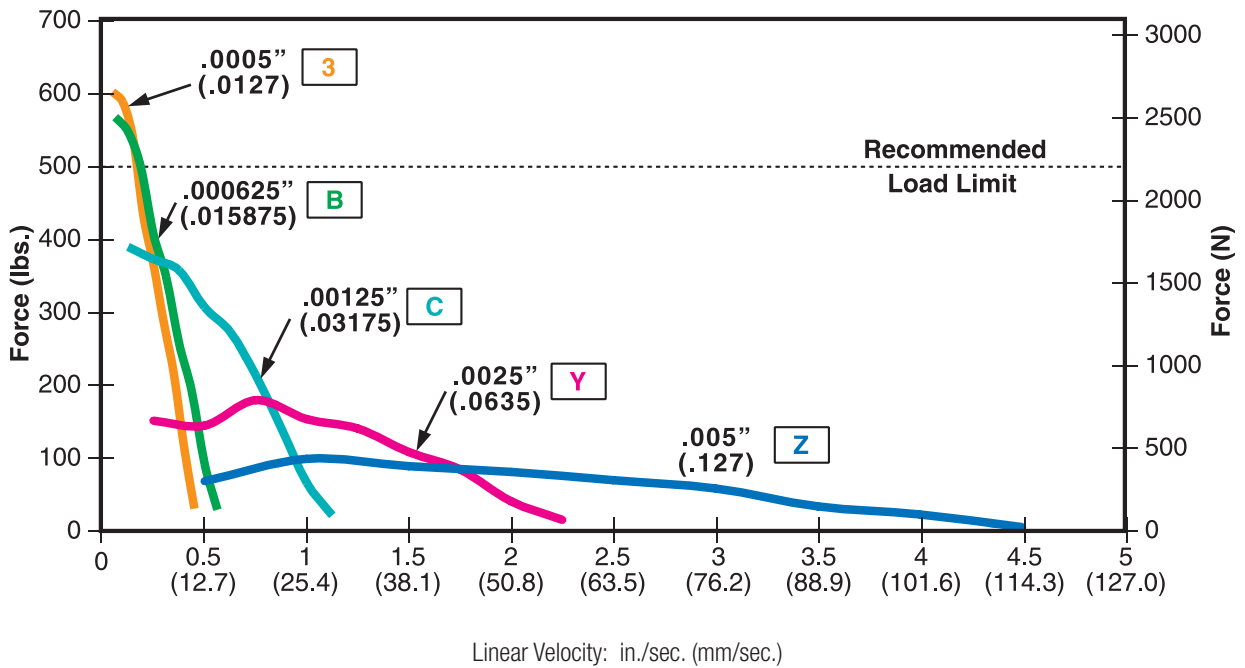

NOTE: All chopper drive curves were created with a 5 volt motor and a 75 volt power supply.

Ramping can increase the performance of a motor either by increasing the top speed or getting a heavier load accelerated up to speed faster. Also, deceleration can be used to stop the motor without overshoot.

With L/R drives peak force and speeds are reduced, using a unipolar drive will yield a further 30% force reduction.

Encoders Designed for All Sizes of Hybrid Linear Actuators

All Haydon Hybrid Linear Actuators are available with specifically designed encoders for applications that require feedback. The compact optical incremental encoder design is available with two channel quadrature TTL squarewave outputs. An optional index is also available as a 3rd channel. The Size 34 encoder is offered in resolutions of 200, 400, 1,000 and 2,000 counts per revolution. Encoders are available for all motor configurations: captive, non-captive and external linear.

Simplicity and low cost make the encoders ideal for both high and low volume motion control applications. The internal monolithic electronic module converts the real-time shaft angle, speed, and direction into TTL compatible outputs. The encoder module incorporates a lensed LED light source and monolithic photodetector array with signal shaping electronics to produce the two channel bounceless TTL outputs.

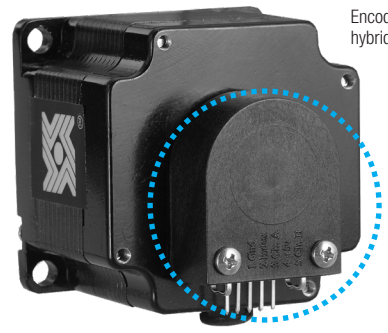

Encoder on Size 23 hybrid motor

57 mm 87000 Series Size 34

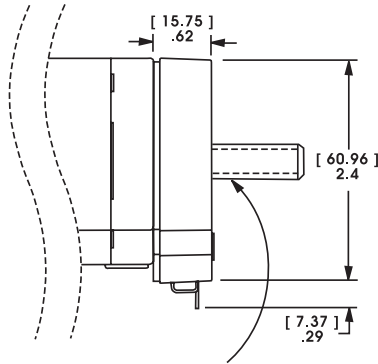

NOTE: Lead Screw extends beyond encoder on specific captive and non-captive motors. External linear shaft extension is available upon request.

Differential Ended Encoder - Pinout - Size 34	
Connector Pin #	Description
1	Ground
2	Ground
3	- Index
4	+ Index
5	Channel A -
6	Channel A +
7	+5 VDC Power
8	+5 VDC Power
9	Channel B -
10	Channel B +

Electrical Specifications				
	Minimum	Typical	Maximum	Units
Input Voltage	4.5	5.0	5.5	VDC
Output Signals	4.5	5.0	5.5	VDC

2 channel quadrature TTL squarewave outputs.
 Channel B leads A for a clockwise rotation of the rotor viewed from the encoder cover.
 Tracks at speeds of 0 to 100,000 cycles/sec.
 Optional index available as a 3rd channel (one pulse per revolution).

Operating Temperature		
Size 34	Minimum	Maximum
	- 40°C (- 40°F)	100°C (212°F)

Mechanical Specifications	
	Maximum
Acceleration	250,000 rad/sec ²
Vibration (5 Hz to 2 kHz)	20 g

Resolution					
4 Standard Cycles Per Revolution (CPR) or Pulses Per Revolution (PPR)					
Size 34	CPR	200	400*	1000	2000
	PPR	800	1600*	4000	8000

*Index Pulse Channel not available.

Single Ended Encoder - Pinout - Size 34			
Connector Pin #	Description	Connector Pin #	Description
1	Ground	4	+5 VDC Power
2	Index (optional)	5	Channel B
3	Channel A		

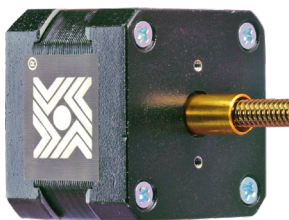

Encoder Ready Option Shown 34000 Series Size 17

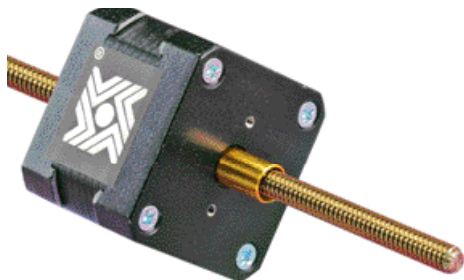

Extended Rotor Journal Shown 34000 Series Size 17

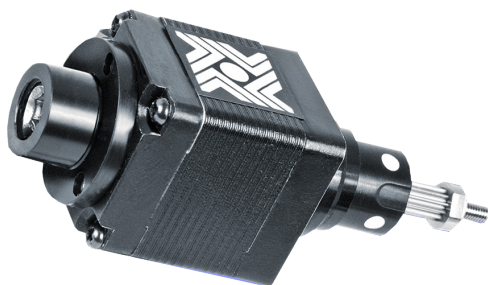

End of Stroke Proximity Sensor



TFE Coated Lead Screw

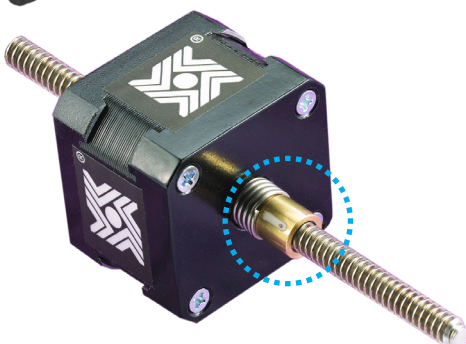

Integrated Anti-Backlash Nut

Encoder Ready Option for all Hybrid Sizes

Our Hybrid Linear Actuators can now be manufactured as an Encoder Ready Actuator. Encoder Ready Actuators can be used to install several popular hollow shaft encoders. Available with an extended rotor journal and a threaded rear housing. The motor uses a proprietary manufacturing process which incorporates engineering thermoplastics in the rotor drive nut and a stainless steel Acme Lead Screw that allows the motor to be much more efficient and durable than today's more commonly used V-thread bronze nut configurations.

Extended Rotor Journal for all Hybrid Sizes

Available with an extended rotor journal. The extended rotor journal can be used for encoder installation, manual adjustment, or flag installation for a positioning sensor.

Home Position Switch for Hybrids

A miniature electronic Home Position Switch capable of monitoring the home positions of linear actuators. The switch mounts on the rear sleeve of captive linear motors and allows the user to identify start, stop or home positions.

When ordering motors with the home position switch the part number should be preceded by an "S" prefix.

End of Stroke Proximity Sensor for all Hybrid Sizes

The Sensor incorporates a hall effect device, which is activated by a rare earth magnet embedded in the end of the internal screw. The compact profile of the sensor allows for installation in limited space applications. The sensor has a virtually unlimited cycle life. Special cabling and connectors can also be provided.

When ordering motors with the proximity sensor, the part number should be preceded by a "P" prefix.

Black Ice® and Kerkote® TFE Coated Lead Screws*

TFE Coated Lead Screws for applications that require a *greaseless* screw and nut interface.

A *dry* (non-lubricated) TFE coated lead screw provides improved performance in both life and thrust as compared to a conventional stainless steel lead-screw. TFE can be applied to a wide variety of lead-screw pitches and is available for our brand captive, non-captive and external linear actuators. Not available for 0.00006-in (.0015 mm) and 0.000098-in (.0025 mm) resolutions.

*Certain conditions apply.

Integrated Anti-Backlash Nut for Hybrids*

Most sizes (except Size 34) of our captive and non-captive hybrid stepper motors can be equipped with an integral anti-backlash feature. There is a normal backlash between the lead screw and integral rotor nut.

Our actuators are designed for millions of cycles. However over time, additional backlash could increase and eventually double. Haydon Kerk Integrated Anti-Backlash Nut can eliminate all backlash. Designed specifically for our captive and non-captive hybrid motors, nuts use an opposing spring force to eliminate backlash between the screw and the nut interface. The nuts will self-compensate and accommodate any wear. Haydon Kerk Motion Solutions application engineers can help you select the appropriate preload for your application.

*Except Size 34.